

***ACTION!*** projectiondesign

SCREEN RECOMMENDATIONS

Whitepaper



### Recommendations in short!

- Always use a 16:9 projection screen with the Action! projectors.
- Select a screen size that is about  $(0.5 - 0.67)x$  your viewing distance, or sit at the equivalent  $1.5 - 2x$  the screen width.
- A permanently wall mounted framed screen is better than a motorised screen is better than a manual screen.
- Always ensure you have a wide, black border around the screen, typically 5 – 10 cm, this provides higher perceived contrast.
- Stay with a low gain screen, typically recommended screens vary between 0.8 – 1.35 gain.
- Smaller screens should be matte grey, larger screens should be matte white.

### Size of screen

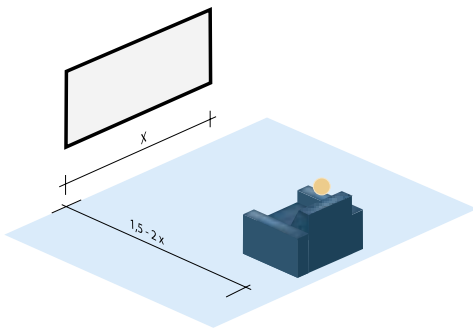

- A large screen size is often the number one reason to buy a projector in the first place. No other technology or product can provide a large image with cinematic feeling at home, and screens well in excess of 100" diagonal are easily available with any projector. A few general "rules of thumb" are good to keep in mind when selecting a screen, and its size.
  - o The dynamic impact and perception of the image is proportional to the size of the image.
  - o A very large screen may be very impressive at first look, but prove less than ideal over time, as you get used to it.
  - o The combination of high brightness and contrast, together with the screen size and material makes up the equation of how dynamic the final image will be, thus what kind of perceived cinema feel it will provide.
  - o The model one, because of its higher brightness, contrast and resolution, is more fit to larger screens.
- Sitting distance
  - o A generally recommend viewing distance is about  $1.5 - 2x$  the screen width. This gives an image that is large, but at the same time not fatiguing when watching a movie or playing computer and TV games.
  - o Some screen manufacturers recommend viewing angles that are about 50 degrees side to side, or screen heights that are one third of the seating distance. All these result in more or less the same screen sizes, within variations of course. The best thing is that you won't get arrested for selecting a screen outside any of these recommendations; some prefer to sit in the first row for a super large image, whereas others prefer the back row. But that may be for other reasons as well?
  - o Recommendations that apply to for instance TVs do not apply to projector screens. Then buy a TV.

- Room size
  - o Room size does matter when selecting a screen size. The length, width and height of the room are important factors. Even though screen size should be selected according to the above, and your own personal preferences, it makes little sense to have an image that is way to big in a small room.
- Recommended screen sizes
  - o With the Action! series performance, optimum image performance will be had with screens from about 200 – 245 cm (80" - 96") wide (90" – 120" diagonal).
  - o These screens will, when correctly set up, yield the best combinations of brightness and impact, black level and colour saturation.

#### Projector brightness and screen gain factors

- A general recommendation from the SMPTE (Society of Motion Picture and Television Engineers) organization emphasizes the needed brightness reflected off the screen in a typical darkened public movie theatre. It reads that the minimum brightness level measured off the screen should be 16 foot lamberts. This is a measurement that takes into account the screen material, its gain factor, the projector brightness and the area of the screen, so is not just projector brightness alone, rather the light reflected off the screen at any one point. The recommended value of 16 foot lamberts is the lowest reading, and most theatres are much brighter, typically in the 25 – 35 area. Interestingly, it is also generally accepted that screens are up to 25% dimmer towards the edges.
- Screen brightness can be approximated by using the following formulae:  
 $(\text{Screen area} \times 10/\text{gain}) = \text{minimum brightness needed.}$   
 As an example; with a 100" diagonal 16:9 typical grey screen, this gives;  
 $29,6 \text{ sqft.} \times 16 \text{ ftL} / 0.8 = \sim 600 \text{ ANSI lumens}$   
 This is to reach the "minimum" brightness recommendation for a fully darkened room.  
 To create a really dynamic image, however, a brighter projector is desired and needed.

#### Types of screens and mountings

- Wall mounted screens are generally recognised as the best screens to use. They are permanently mounted on the wall, with a large frame to suspend the screen material, in order for it to never become wavy or de-tensioned. The frame should ideally be black (see below), to increase perceived contrast. Unfortunately, the WAF (Wife Acceptance Factor) of a permanently mounted screen is not very high, and performance will sometimes have to be sacrificed for the peace of living.

- Motorised screens are the second best. As there is no stress applied to the material itself, rather just the drum to which it is fastened, the screen surface will only be minimally stretched, thus provide an image with a minimum of visual artefacts caused by the screen. If possible, select a screen that is “tensioned”, by using wires on the sides.
- Manual screens are very common, but unfortunately the lowest quality available. Simple put, this is because that whenever a manual screen is used, it will be pulled up and down from a spring tensioned drum. Typically, this will be done using one hand, at the middle of or at the side of the screen, using a pull handle or a string. This applies a lot of tension to the screen, and everything has to go through the material itself. Depending on the quality of the material, the fixing to the lower bar and the drum, this inevitably results in a screen that will suffer from severe distortion that can be seen as a large “V”. As a result, projected images will be distorted similarly. When purchasing a quality projector, it is well worth considering upgrading to a motorised or permanent screen where possible. It will improve the quality of the image, and over time be well invested money.

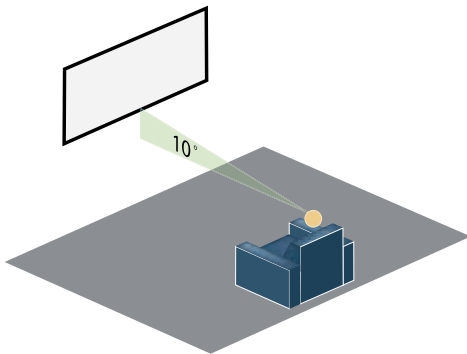
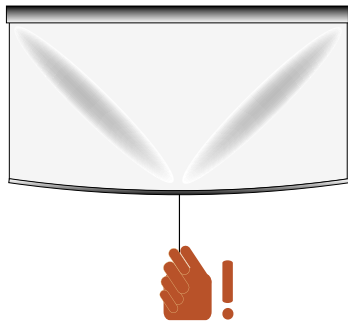

#### Placement of screen

- The screen and projected image should be placed in such a way that the viewing angle when sitting down is not stressful. Placing a screen too high up on the wall will be fatiguing, and discourage use of the system. Ideally, the viewer should sit relaxed, and have the screen straight forward or at a slightly upward angle. This is relatively easy to achieve in most rooms.

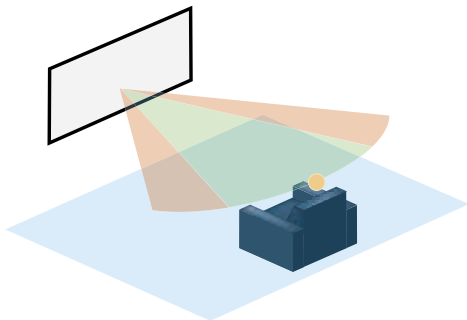

#### Preferred screen materials and gain factors

- Generally, low gain screens are much desired in the home theatre. A low gain screen can have a gain factor in the range of 0.8 – 1.35.
- “Screen gain” refers to the screen material’s ability to “increase or decrease” and direct light from the projector in a desired direction, thus increase or decrease perceived brightness of the projector itself. High gain (>1.5) screens are typically used in office and other bright environments, in order to improve viewing quality when ambient light cannot easily be controlled. High gain screens are highly directional, and generally not suited for home cinema or critical viewing use.
- A low gain screen ensures you will not experience expressed “hot spotting”. The phenomenon can be described as if a part of the screen appears to be brighter than other parts, and the brighter part moves with you and follows you when moving from side to side. A matte low gain screen disperses light in all directions, and avoids this phenomenon, and is better suited for video viewing.

White and grey screens – or screen materials.

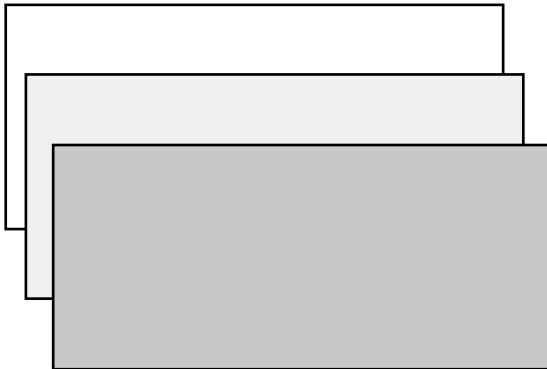

- There are generally two types of screens available; white screens and grey screens. The white screen is the classic projection screen, with very neutral colour balance properties, and great dispersion patterns. It has been used for ages when projecting 8mm film, slides and alike, and is a safe bet. Grey screens have been developed lately to improve black level performance of high output digital projectors with limited contrast. They are grey in colour, and decrease the amount of light reflected, whereby the different grey levels of projectors are experienced as dimmer, thus providing a “blacker black” than a white screen will.
- Tastes are different, and so is the preferred screen material selection! Some people will prefer white screens, whereas some people will prefer a grey screen. It is generally accepted to recommend a grey screen for most digital projectors, and also for certain screen sizes.
- With any screen up to about 230 cm (7-8 ft) wide, the Action! series will be happy with grey screens in darkened home theatre environments. This will give the best balance between dynamics, brightness, contrast and black level. So matte grey screens ideally lower black level and keeps your peak white under control, while retaining colour fidelity and neutrality. There are several types of grey screens available, each having different names and materials, but all sharing the same basic ideas.
- For larger screens, white screens are more suited, as they will keep the dynamics intact (also see “projector brightness and screen gain factors” above), as well as give a great and suitably bright image.
- Although we do not generally recommend perforated screens, there are alternatives. Perforated screens allow speakers to be placed behind them in order to have dialogue coming from the image itself, but normally influence both the image and the audio, in one or more ways. A perforated screen has been talked about as “not always very bad, but never good”. Most perforated screens will also be translucent to light, and will reduce dynamics and contrast. Besides, most perforated screens will result in “covering the speaker in drapes or tissue paper”, and heavily influence the sound itself, resulting in loss of treble and amplitude, thus presence and coherence of the audio itself. An alternative is to look at for instance screens from Screen Research, both THX and ISF certified, with minimal influence on both audio and video.

- Normal perforated screen are generally very bad, as the holes in the screen interact with the pixel structure of the projector, and create disturbing moiré patterns in brighter areas. That will totally ruin a good image!



#### Screen essentials

- It is essential to have a wide (5-10 cm) black frame around the projected image, a frame that perfectly outlines the projected image area and aspect ratio (with the Action! projectors, generally 16:9 wide format screens). The black frame acts as your eyes' reference, and thereby increases perceived contrast quite dramatically. Normal living rooms used as home theatres very rarely have black or dark walls, and the black frame is used as a substitute for this. If there is no reference for the eye, it will automatically cancel out the contrast of the image!
- For use with the Action! projectors, always use 16:9 widescreen format projection screens. The native resolution of the projector is widescreen.

©2005 projectiondesign as